

The Comrod family of CAPAS® Automatic Payload Alignment Systems are designed to meet the challenges faced by public safety, defence and demanding industrial users. CAPAS® systems enables quick and effective deployment of communication or sensor assets in extreme environments without exposing personnel to unnecessary danger.

CAPAS-SR Single Rotator System accomplishes this by enabling 360 degree azimuth rotation of a wide range of payloads.

CAPAS-SR supports both closed loop and open loop alignment, and allows a combination of both. In closed loop alignment mode the system is controlled by a radio transceiver to optimize received signal strength or minimize bit error rate. In open loop alignment mode the system is controlled by the Comrod Integrated Mission Planning System. The powerful drive system coupled with the optional fully integrated GPS compass allows fast and accurate positioning of payloads demanding better than 1.5 degree pointing accuracy. Closed loop feedback from the radio can optimize the alignment within a fraction of a degree.

CAPAS-SR is fully rugged per MIL-STD-810, and is suitable for a wide range of deployable masts, including Comrod TM, LMT and ULM series.



CAPAS -SR rotator with Comrod band 3+ antenna mounted on a Comrod TM210 electro-mechanical mast

Features

| | |
|---------------------------------|---|
| Power Supply | 18 to 52 VDC (MIL-STD 1275E) |
| Alignment Modes | Closed loop mode with transceiver control Open loop mode with magnetic or DGPS compass control Hybrid mode |
| Planning Tool (Optional) | Integrated Mission Planning System |
| Pointing Accuracy | ~ 0.5 degree relative to base |
| Rotating Speed * | > 10 degrees per second * |
| Operating Temperature (Ambient) | -40°C to +60°C (-40°F to 140°F) |
| Torque * | >50Nm Dynamic *, >250Nm Static (survival) |
| Payload Capacity * | 20kg (maximum in-balance load) * |
| Dimensions (nominal) | W = 31cm, H = 60cm, D = 29cm (~12.2 x 23.6 x 11.4 in) |
| Weight (approx.) | 11kg (~24 lbs) |
| Mounting | Lower socket, 50.5mm Upper payload mounting spigot 50mm Adaptors are available for a wide range of payloads and masts |

* Dependent on power supply and payload weight/area

| Characteristic | Standard |
|-----------------------|---|
| Interfaces | CAN, RS232, RS485 or Ethernet (not all available together) |
| Vehicle Power | MIL-STD 1275E |
| EMC/EMI | MIL-STD-461F CE102, RE102, RS103, CS101, CS114, CS115 and CS116 |
| Wind Rating (Max) | 150 km/h (94 mph), when fitted with typical Comrod Band 4 antennas (see below) |
| Operating Temperature | Ambient: --40°C to +60°C (-40°F to 140°F) |
| Encapsulation | IP67 |
| Sand and Dust | MIL-STD-810G METHOD 510.5 Procedure I and II |
| Altitude | Operational - MIL-STD-810G: Method 500.5, Procedure II, 4572 m (15000 ft) at 57.2 kPa Storage - MIL-STD-810G: Method 500.5, Procedure I, 12192 m (40000 ft) at 18.8 kPa |
| High temperature | Operation: MIL-STD-810G, Method 501.5, Procedure II , 60°C Storage: MIL-STD-810G, Method 501.5, Procedure I, 71°C |
| Low temperature | Operation: MIL-STD-810G, Method 502.5, Procedure II, - 40°C Storage: MIL-STD-810G, Method 502.5, Procedure I, -51°C |
| Humidity | MIL-STD-810G, Method 507.5, Procedure II, Aggravated |
| Vibration * | MIL-STD-810G, Method 514.6C Table 514.6C-VI. Composite wheeled vehicle vibration exposures figure 514.6C-3 * MIL-STD-801G, Method 514.6D, Ground Vehicle Category 20, Wheeled/Tracked/Trailer, Procedure I/III * |
| Shock * | MIL-STD-810G, Method 516.6, Procedure I, functional Shock, 12g 11ms * |

* Unit without payload. Permanent mount required for high shock/vibration environments

Mounting Details

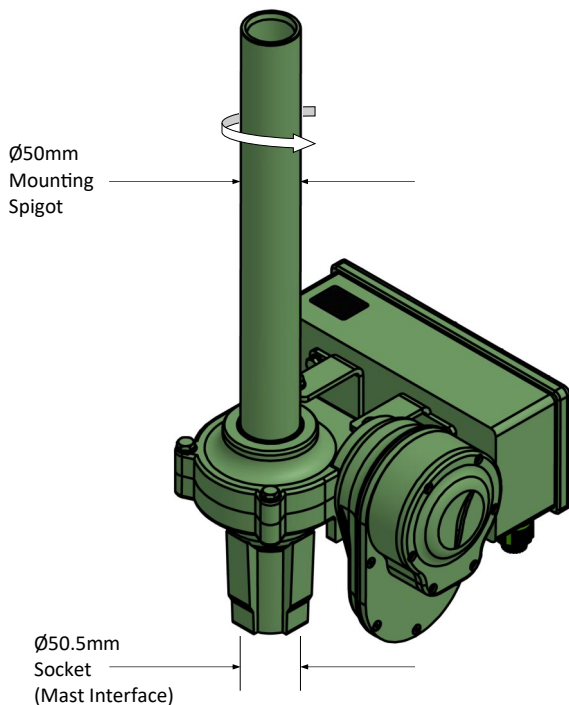

Outline Drawing

